

PUMPS

QR Series - Pumps For Commercial Pools

Features:

- High efficiency self-priming centrifugal pumps with built-in extra large prefilter.
- Extremely quiet running and great reliability developed for water circulation.
- Pump body, prefilter & pump foot in PP.
- Strainer cover in see through polycarbonate to guarantee constant visibility and easy inspection.
- Pump prefilter body closed with knob system for easy accessibility.
- Diffuser & Impeller in PPO.
- Mechanical seal in SIC.
- Motor casing in die cast aluminum L2521.
- Asynchronous continuous duty 2-pole motor with F class insulation motor and terminal box protection rating: IP55.
- Ball bearings-water-proof, sealed, resistant to water and humidity.
- Standard voltage: three phase 230/400V 50Hz.
- Liquid temperature range: up to 50°C.
- Maximum ambient temperature: up to 50°C.
- Maximum operating pressure: 2,5 bar.
- Installation: fixed or portable in horizontal position.
- Union connectors with 110/90 mm BS pipe sockets.

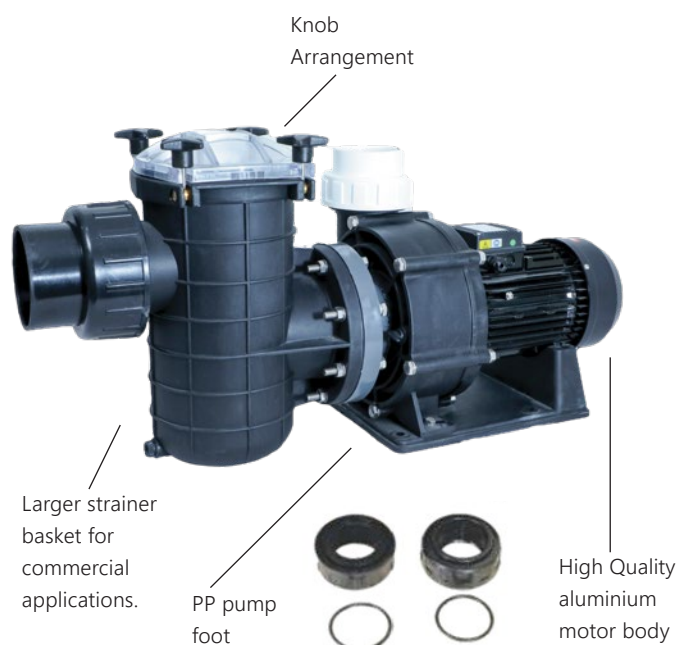

Technical Specification

Ref. Code	HP	KW	V	A	P1(KW)	Q	L/min M ³ /h	0	333.3	500	666.7	833.3	1000	1166.3
			3~	3~				0	20	30	40	50	60	70
QRC300T	3.0	2.2	380	4.9	2.8	H(m)	13	12.6	11.8	10.6	9			
QRC400T	4.0	3.0	380	6.4	3.6		14.5	14.2	13.5	12.6	11	9.5		
QRC550T	5.5	4.0	380	8.3	4.7		18.2	17.8	17	16.3	16	13.8	12.2	

PUMPS

QR series - Pumps for Commercial pools

Performance Curves

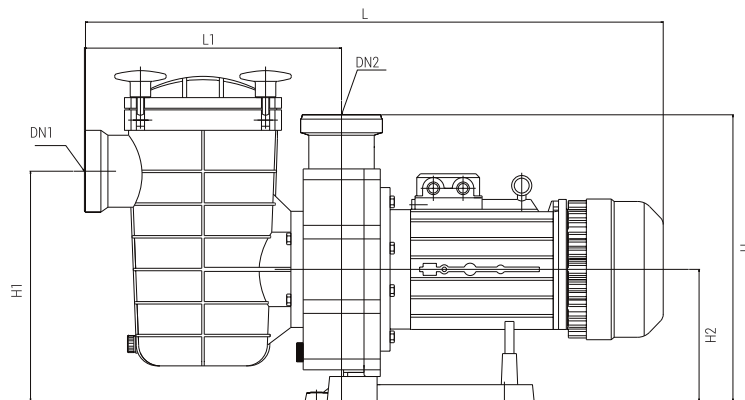
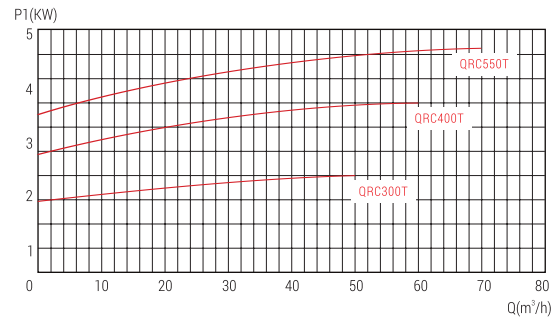
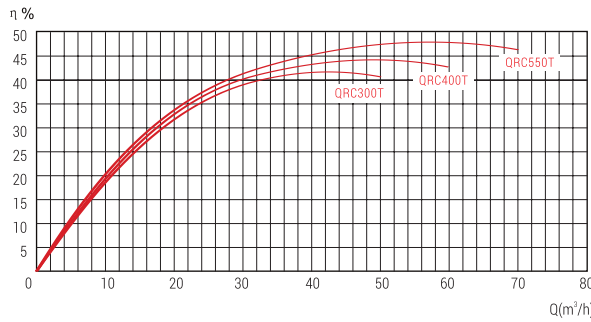
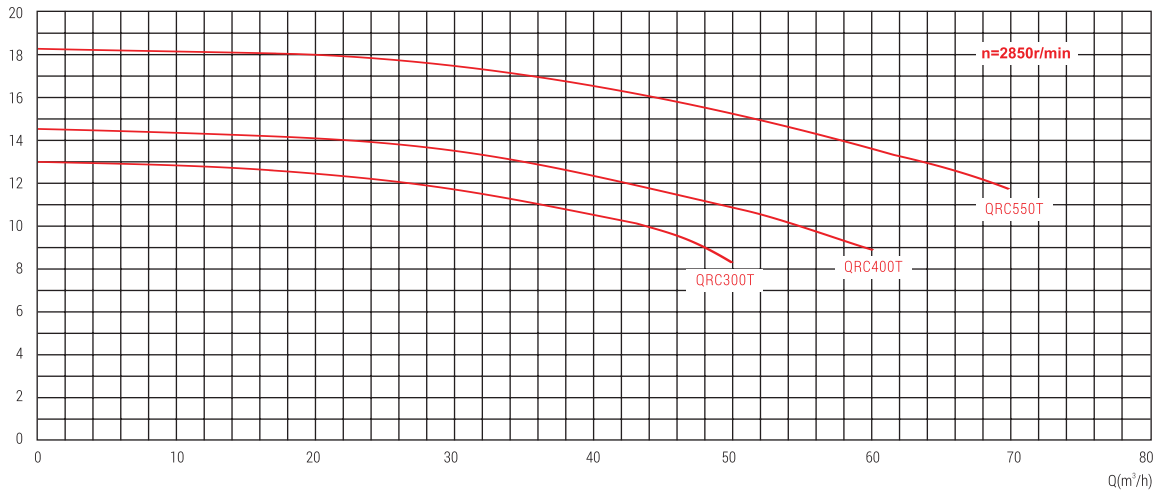

Dimensions (in mm)

Ref. Code	L	L1	H	H1	H2	DN1	DN2
QRC300T	833	310	319	286	156	110	90
QRC400T	833	310	319	286	156	110	90
QRC550T	850	310	319	286	156	110	90