

# PUMPS

## QR series - Pumps for Large Commercial pools

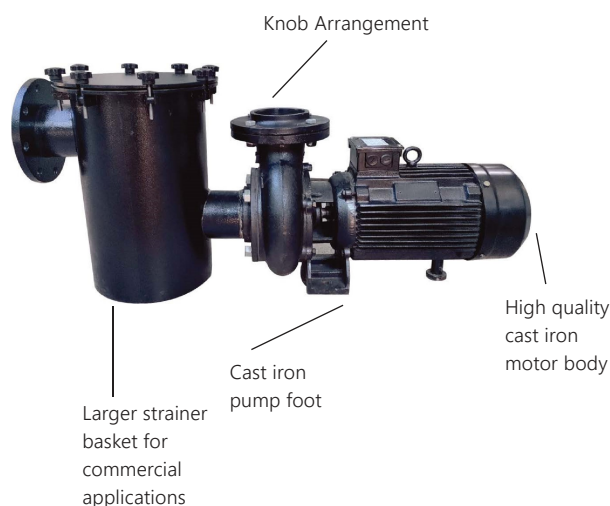

### FEATURES:

- High efficiency self-priming centrifugal pumps with built-in extra large prefilter.
- Extremely quiet running and great reliability developed for water circulation.
- Pump body, prefilter & pump foot in specially coated cast iron
- Pump prefilter body closed with a knob system for easy accessibility.
- Diffuser & Impeller in cast iron.
- Mechanical seal in SIC.
- Motor casing in cast iron.
- Asynchronous continuous duty 2-pole motor with F class insulation motor and terminal box protection rating: IP55.
- Ball bearings - water - proof, sealed, resistant to water and humidity.
- Standard voltage: Three-phase 400V 50Hz.
- Liquid temperature range: up to 50°C.
- Maximum ambient temperature: up to 50°C.
- Maximum operating pressure: 2,5 bar
- Installation: fixed in horizontal position only.
- Flange connections (100 x 65 upto 10HP, 125 x 125 for 12.5HP & above).

### TECHNICAL SPECIFICATION

Ref. Code	HP	KW	V		A	P1(KW)		Q	L/min	0	500	750	1000	1250	1500	1916	2250	2483	2633	2750	3000	3250	
			3~	50Hz	3~	220	380																
QRC550T	5.5	4	220	380	8.3	4.7	4.7	H(m)	18.5	17.5	16	14	10										
QRC750T	7.5	5.5	220	380	11.0	6.3	6.3		21	20.5	19.5	17.5	14	8									
QRC1000T	10	7.5	220	380	14.8	8.6	8.6		24	23.5	23	21.5	18	15									
QRC1250T	12.5	9.2		380	17.9		10.5		20						18	17	15	14	13	12	9		
QRC1550T	15	11		380	21.0		12.5		22						20.5	19.5	18	17	16	15	12	10	

# PUMPS

QR series - Pumps for Large Commercial pools

## PERFORMANCE CURVES

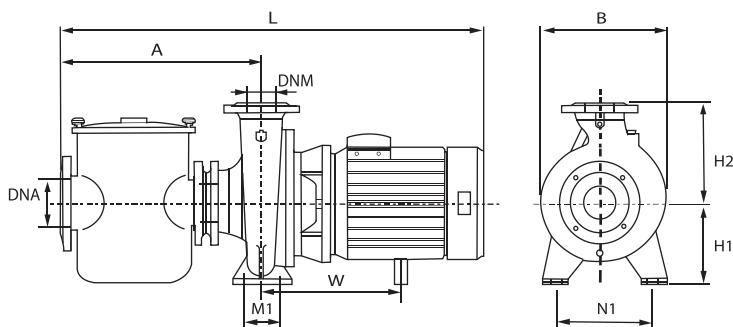
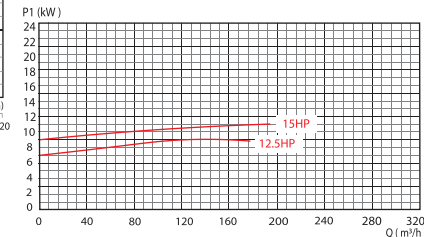
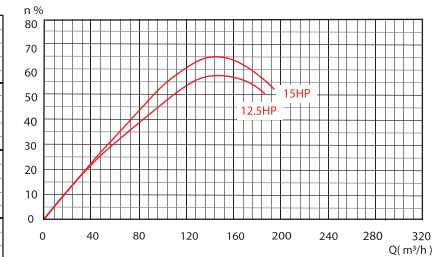
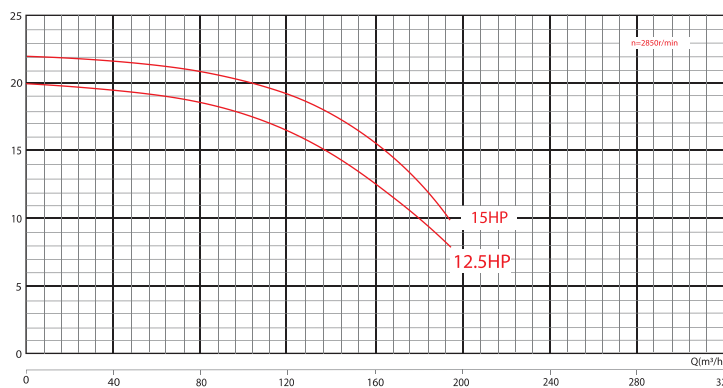
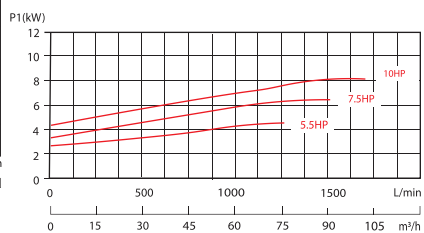
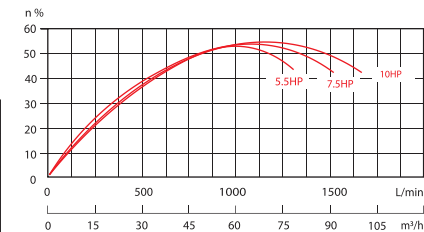
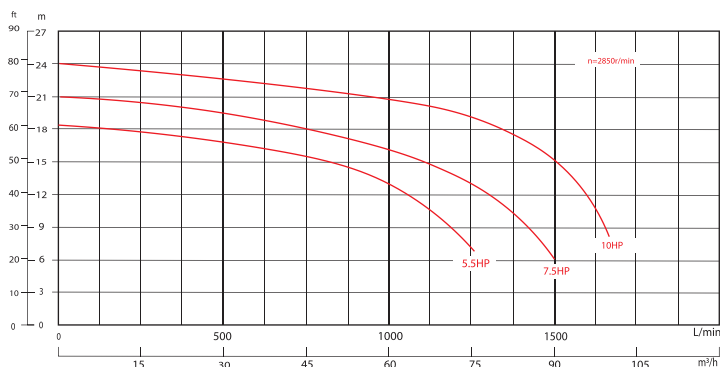

## DIMENSIONS IN (MM)

Ref. Code	A	B	M1	W	L	N1	H1	H2	DNA	DNM
QRC550T	495	310	95	292	970	212	162.5	180	Ø100	Ø65
QRC750T	495	310	95	310	995	212	162.5	180	Ø100	Ø65
QRC1000T	495	310	95	310	995	212	162.5	180	Ø100	Ø65
QRC1250T	489	322	95	262	990	187	160	236	Ø125	Ø125
QRC1550T	489	322	95	275	1016	187	160	236	Ø125	Ø125